

PRORIL

60Hz

Designed for light weight, excellent performance, low energy consumption, and easy maintenance, PRORIL submersible handy pumps serve a wide range of pumping applications on utility, construction, industrial, and municipal job sites.

Handy and Residue Pump **SMART 1500**

Handy Pump



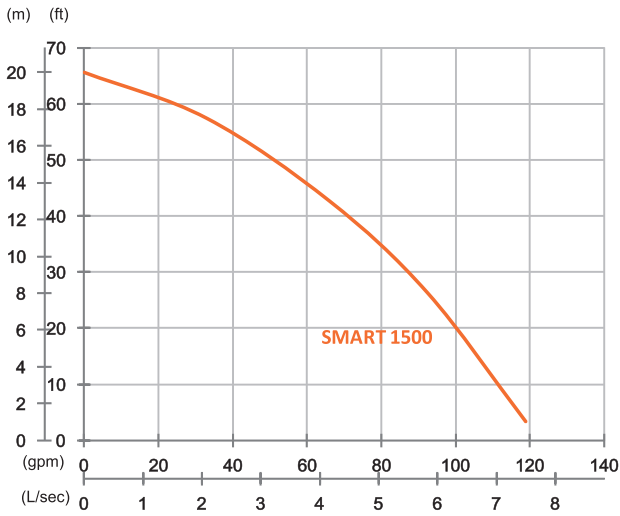

SMART 1500

OUTPUT	2 HP (1.5 kW)
OUTLET	2" (50 mm)
SOLID PASSAGE	0.4" (9 mm)
Weight	53 lbs/24 kg
HEAD	Rated: 43 ft, 13 m Max: 66 ft, 20 m
FLOW	Rated: 66 gpm, 4.2 L/s Max: 119 gpm, 7.5 L/s

Pump Type	Electric Submersible Pumps	
Motor	Phase	1-Phase, 3-Phase
	Type	Induction Motor
	Poles	2 Pole (3450 rpm)
	Insulation	Class F
	Protector	Circle Thermal Protector
	Starter	1-Phase • Capacitor-Run, 3-Phase • D.O.L
Lubricant	Food Grade (ISO VG32)	
Specs.	Impeller Type	Opened
	Shaft Seal	Double Mechanical Seal
		Silicon Carbide VS Ceramic/Carbon
	Bearings	C3 Shielded ball bearings
	Cable	CSA-Certified PVC Jacketed Cables
33 ft (10 m) or longer upon request		
Materials	Pump Casing	Gray Iron
	Impeller	Gray Iron
	Motor Frame	Stainless Steel
	Motor Shaft	Stainless Steel
	Outer Case	Stainless Steel
	Strainer	Stainless Steel
Max. Liquid Temperature	40°C (104°F)	
Max. Submersion Depth	20 m (66 ft)	
pH Range	pH 5 - pH 8	

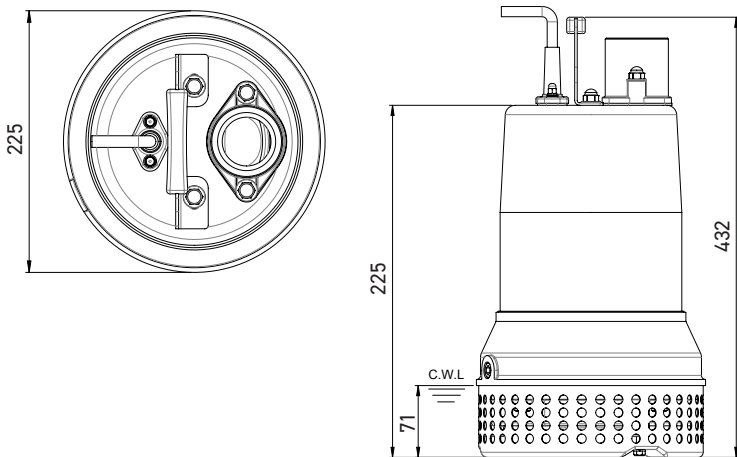

unit : mm
C.W.L : Continuous running water level